



Clearview Accessibility Advisory Committee
ACCESSIBILITY AUDIT

May 14, 2019 at 5:00 p.m.
Avening Community Centre
3401 County Road 42 Creemore, ON

1. Approval of Agenda

Recommendation:

Be It Resolved that the Accessibility Advisory Committee hereby approve the Agenda dated May 14, 2019 as presented.

2. Disclosure of pecuniary interest and the nature thereof

3. Accessibility Audit – Avening Community Centre

Committee members will be conducting an accessibility audit of the Hall. Each member has been provided with an audit checklist to complete.

4. Adjournment

Recommendation:

Be It Resolved that the Accessibility Advisory Committee Meeting be adjourned at _____ p.m.

FADS AUDIT CHECKLIST

Things to consider when using this document is to remember there are provisions with-in the renovations section starting on page 138 of the FADS document.

Abbreviations in this checklist are:

OBC: Ontario Building Code

TWSI: Tactile Walking Surface Indicators

AFF: At Finished Floor

Building Entrance and Doors

ITEM	YES / NO / N/A	FADS REFERENCE	COMMENTS
Entrance clearly marked by international symbol of accessibility		Section 11&13 pg. 43/51	
Entrance has Barrier-free path of travel leading to sidewalk		Section 13 pg. 51	
Door width 900mm		Section 14 pg. 52	
Door has power operator		Section 15 pg. 56/57	
Vestibule door has power operator 2500mm clear floor space between doors		Section 14&15 pg. 55/56/57	
Door sill 13mm (1/2") high		OBC	
Door/frame has colour contrast to wall(s)		Section 14 pg. 52	
Door hardware operable with closed fist (lever type)		Section 14 pg. 53	

Service Counter

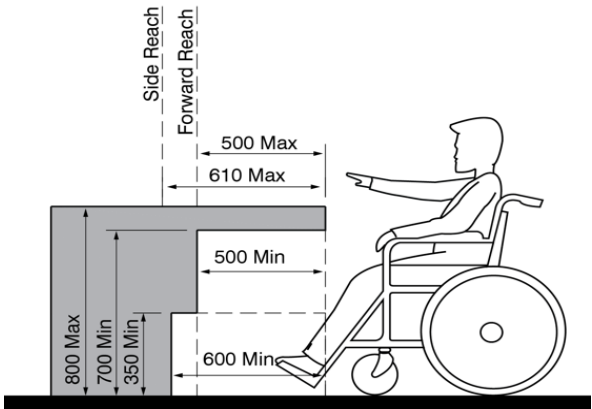
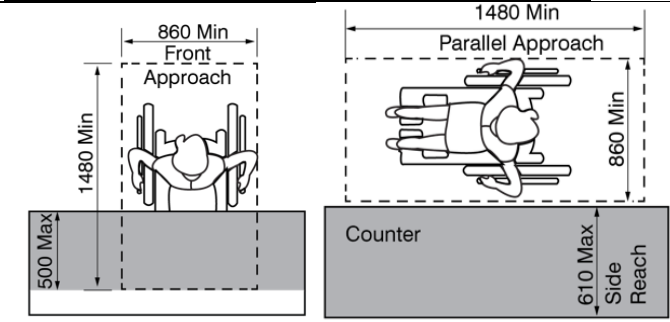
ITEM	YES / NO / N/A	FADS REFERENCE	COMMENTS
Be clearly identified with signage		Section 18 pg. 63	
		Section 18 pg. 64	
		Section 18 pg. 64	

Barrier-Free Path of Travel (Interior)

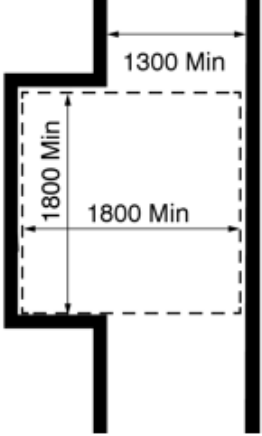
ITEM	YES / NO / N/A	FADS REFERENCE	COMMENTS
Path width 1800mm Primary		Section 2 pg. 22	
Path width 1300mm Secondary		Section 2 pg. 22	
Path width around work stations 1100mm		Section 2 pg. 22	
Path width alternative <1800mm provide a passing area every 30m 		Section 2 pg. 22/23	
Surface stable, firm, level		Section 3 pg. 25	
Light levels to 200 Lux		Section 10 pg. 41	
Protruding Objects not more than 100mm unless cane detectable at or below 680mm AFF		Section 4 pg. 27	
Protruding Objects headroom 2100mm AFF		Section 4 pg. 27	
Controls (light switch/intercom) to be located between 900mm to 1100mm AFF		Section 9 pg. 40	
Controls (thermostat/fire alarm) to be located at 1200mm AFF		Section 9 pg. 40	
Controls outlets to be min. 400mm AFF		Section 9 pg. 40	
Controls Clear Floor Area 860mm wide x 1480mm long		Section 9 pg. 39	
Acoustics Sound reducing design to reduce echoing		Section 12 pg. 47	
Colour contrasting walls to doors to controls to flooring		Section 3,9,12 pg. 25,39,46	
Signage (directional, washrooms, etc.) [Can I get there from here?]		Section 11 pg. 43,44,45	
Signage to be 1200mm max AFF		Section 11 pg. 44	

Barrier-Free Path of Travel (Exterior)

ITEM	YES / NO / N/A	FADS REFERENCE	COMMENTS
Path width 1500mm Primary and secondary		Section 38 pg. 107	
Path width <1800mm provide a passing area every 30m		Section 38 pg. 107	
Edge protection required at changes to grade between 200mm and 600mm except at stairs		Section 38 pg. 107	
Path surface must be able to drain		Section 38 pg. 108	
Path to have colour contrast		Section 38 pg. 108	
Ground must be firm, level, and stable		Section 3 pg. 25	
TWSI required as per Section 8 pg. 40, 41, 42		Section 39 pg. 110	
TWSI is to identify a hazard like entry to vehicular route or area where no curbs.		Section 8 pg. 36	

Stairs and Ramps and Handrails

ITEM	YES / NO / N/A	FADS REFERENCE	COMMENTS
Ramp clear width of 1100mm		Section 5 pg. 28	
Ramp max slope 1 in 20 (5%)		Section 5 pg. 28	
Handrails required on both sides of ramp		Section 5 pg. 30	
Colour contrast for the beginning and end of ramp		Section 5 pg. 30	
Edge protection required if no wall or guard installed and must be 75mm in height		Section 5 pg. 30	
Landings on ramps top and bottom to be 2500mm x 2500mm and intermediate with 180 degree turn		Section 5 pg. 28	
Landings on ramps with 90 degree turn min. 1670mm x 1670mm		Section 5 pg. 28	
Stairs have a rise between 125mm and 180mm		Section 6 pg. 31	
Stairs have a run between 280mm and 355mm		Section 6 pg. 31	
Stairs to be uniform		Section 6 pg. 31	
Guards required on both sides of stairs > 600mm AFF		Section 6 pg. 32	
Stair nosing to have colour contrasting strip extending the full width of the tread and be slip resistant		Section 6 pg. 32	
TWSI to be a min 920mm wide be located one tread depth back from the first stair at the top and at intermediate landings where a door opens onto a landing		Section 6 pg. 32	
Handrails to be on both sides of stairs		Section 7 pg. 34	
Handrail height to be between 865mm to 965mm		Section 7 pg. 34	
Handrail to extend 300mm top and bottom of stairs		Section 7 pg. 34	
Handrail to be colour contrasting to wall		Section 7 pg. 34	

Handrail to have 50mm clearance between wall and handrail, 60mm if the wall is rough surface		Section 7 pg. 34	
Handrail to have a cross-sectional diameter of 30mm to 40mm		Section 7 pg. 34	

Washrooms with Stalls

ITEM	YES / NO / N/A	FADS REFERENCE	COMMENTS												
<p>[Table 20.1] Number of Accessible Water Closets Required</p> <table border="1"> <thead> <tr> <th>Number of Water Closet Stalls</th> <th>Number of Accessible Water Closet Stalls Required</th> </tr> </thead> <tbody> <tr> <td>1-9</td> <td>1</td> </tr> <tr> <td>10-16</td> <td>2</td> </tr> <tr> <td>17-20</td> <td>3</td> </tr> <tr> <td>21-30</td> <td>4</td> </tr> <tr> <td>Greater than 30</td> <td>5 + 1 for every additional 10 water closet stalls</td> </tr> </tbody> </table>	Number of Water Closet Stalls	Number of Accessible Water Closet Stalls Required	1-9	1	10-16	2	17-20	3	21-30	4	Greater than 30	5 + 1 for every additional 10 water closet stalls		Section 20 pg. 68	
Number of Water Closet Stalls	Number of Accessible Water Closet Stalls Required														
1-9	1														
10-16	2														
17-20	3														
21-30	4														
Greater than 30	5 + 1 for every additional 10 water closet stalls														
Where accessible water closets are not provided in a gender specific washroom and the universal washroom is not visible from the entrance to the common or multi-stall washroom, directional signage must be provided and meet requirements in section 11.		Section 20 pg. 71													
Accessible stall must have a door 900mm clear width and have gravity hinges and swing outward and be colour contrasting to the stall walls		Section 20 pg. 68													
		Section 20 pg. 69													

<p>1200 Max</p> <p>Collapsible coat hook</p> <p>Toilet paper dispenser</p> <p>390-410</p> <p>150</p> <p>840-920</p> <p>430-460</p> <p>750</p> <p>460-480</p>		Section 20 pg. 72	
<p>Toilet paper dispenser</p> <p>30-40</p> <p>760</p> <p>760 Min</p> <p>30-40</p> <p>760 Min</p> <p>25-50</p> <p>600</p> <p>150</p> <p>750</p> <p>150</p> <p>840-920</p> <p>in line or Max 300 from toilet seat</p>		Section 20 pg. 72 Section 21 pg. 74	
<p>860 x 1480 500 Max permitted under lavatory</p> <p>Power Door Operator</p> <p>460 Min</p> <p>600 Min</p> <p>1400 Min</p> <p>1700 Min</p> <p>1800</p> <p>1800</p> <p>680 AFF Max</p> <p>Urinal Screen</p> <p>920 Min</p> <p>460 Min</p> <p>480 Min</p> <p>480 Min</p> <p>460 Min</p> <p>Clear transfer space for water closet stall 900 x 1500</p> <p>Clear floor space for urinal 860 x 1480</p>		Section 20 pg. 73	

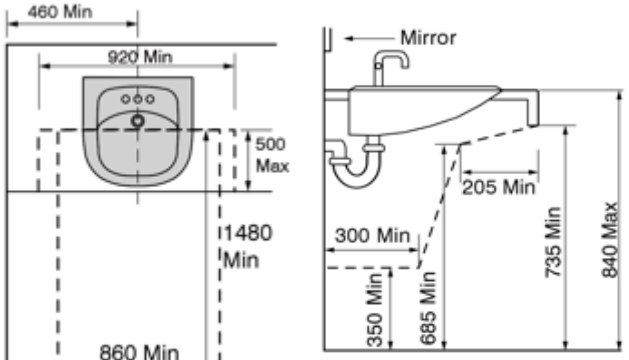
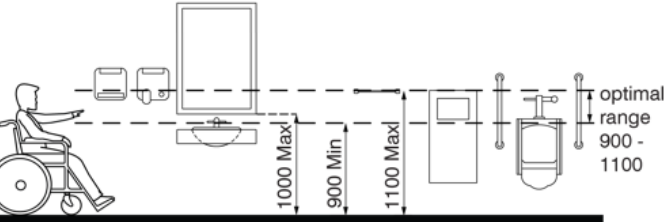
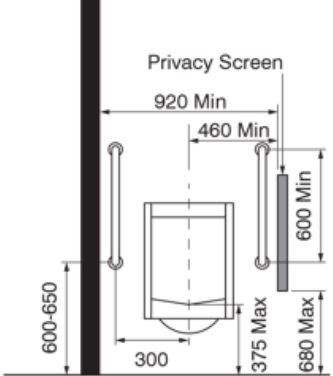
 <p>[Diagram 22.A] Lavatory Design</p>		Section 22 pg. 76	
Provide at least one accessible lavatory in every accessible washroom		Section 22 pg. 76	
Faucet handles must be lever type or automatic		Section 22 pg. 77	
Exposed pipes must be insulated to prevent burns		Section 22 pg. 77	
Soap and towel dispensers must be located max 610mm from the front edge of the lavatory & meet section 23		Section 22 pg. 77	
 <p>[Diagram 23.A Washroom Accessory Mounting Heights</p>		Section 23 pg. 78	
 <p>[Diagram 21.B] Accessible Urinal with Grab Bars Front Elevation</p>		Section 21 pg. 75	

Universal washroom

ITEM	YES / NO / N/A	FADS REFERENCE	COMMENTS
<p>460 Min</p> <p>Clear floor space beside water closet 900 x 1500</p> <p>Fold down grab bar</p> <p>460 - 480</p> <p>Clear floor space in front of lavatory 860 x 1480 (500 permitted to be under lavatory)</p> <p>2500</p> <p>Fold Down Adult Change Table</p> <p>810</p> <p>1830</p> <p>900 Min</p> <p>600 Min</p> <p>Power Door Operator</p>		Section 24 pg. 80	
At least one universal washroom must be provided on every floor in addition to any accessible multi-stall washrooms & no further than 45m from multi-stall washrooms		Section 24 pg. 79	
Grab bars to be the same as previous page under multi-stall washrooms		Section 21 pg. 74	
Washroom accessories same as previous page		Section 23 pg. 78	
Lavatory requirements same as previous page		Section 22 pg. 76	
Adult change table to be 865mm AFF		Section 24 pg. 80	
<p>Emergency Call System must have a visual and audible signal device inside and outside of the universal washroom and connected to an occupied reception or security desk. Signage must be provided "In the event of an emergency, push emergency button & audible & visual signal will activate" Letters must be min. 25mm tall with a 5mm stroke that is posted above the emergency button. Sign must be tactile & braille.</p> <p>The emergency button must be located within reach of the water closet but not be located to be accidentally pulled when reaching for toilet paper or grab bars. The button is to be mounted between 900mm and 1200mm AFF.</p>		Section 24 pg. 80	
Occupied signal must be located outside of the universal washroom mounted between 900mm and 1200mm AFF and be illuminated when the push to lock button on the inside of the universal washroom is activated.		Section 24 pg. 81	

Parking

ITEM	YES / NO / N/A	FADS REFERENCE	COMMENTS												
Parking spaces, access aisles and path to the building to be firm, stable, and slip resistant		Section 41 pg. 117													
Have running slope max 1 in 20 (5%)		Section 41 pg. 117													
Have a cross slope max 1 in 50 (2%)		Section 41 pg. 117													
Be painted blue with international symbol (white) size of symbol to be 1560mm x 1290mm		Section 41 pg. 117													
Parking signage mounted 1500mm to 2500mm from centre of sign to ground surface in front of parking space		Section 41 pg. 117													
The amount of accessible parking must be 50% Type A and 50% Type B. If odd number of spaces the remaining can be Type B		Section 41 pg. 115													
<table border="1" data-bbox="128 548 485 1096"> <thead> <tr> <th data-bbox="128 548 312 792">Total Number of Parking Spaces</th> <th data-bbox="312 548 485 792">Amount of Accessible Parking Spaces Required Type A and B</th> </tr> </thead> <tbody> <tr> <td data-bbox="128 792 312 857">Less than 12</td> <td data-bbox="312 792 485 857">1 Type A</td> </tr> <tr> <td data-bbox="128 857 312 911">13 to 100</td> <td data-bbox="312 857 485 911">4% of total</td> </tr> <tr> <td data-bbox="128 911 312 964">101 to 200</td> <td data-bbox="312 911 485 964">3% of total</td> </tr> <tr> <td data-bbox="128 964 312 1018">201 to 1000</td> <td data-bbox="312 964 485 1018">2% of total</td> </tr> <tr> <td data-bbox="128 1018 312 1096">Greater than 1000</td> <td data-bbox="312 1018 485 1096">1% of total plus 11</td> </tr> </tbody> </table>	Total Number of Parking Spaces	Amount of Accessible Parking Spaces Required Type A and B	Less than 12	1 Type A	13 to 100	4% of total	101 to 200	3% of total	201 to 1000	2% of total	Greater than 1000	1% of total plus 11		Section 41 pg. 115	
Total Number of Parking Spaces	Amount of Accessible Parking Spaces Required Type A and B														
Less than 12	1 Type A														
13 to 100	4% of total														
101 to 200	3% of total														
201 to 1000	2% of total														
Greater than 1000	1% of total plus 11														
Accessible paths shall be provided from the building to the accessible parking		Section 41 pg. 115													
Where possible the path must not enter vehicle traffic and should be as short as possible		Section 41 pg. 115													
Access aisle min. width 1500mm		Section 41 pg. 115													
Parking space for Type A 3650mm and min. length 5700mm		Section 41 pg. 115													
Parking space for Type B 2700mm and min. length 5700mm		Section 41 pg. 115													

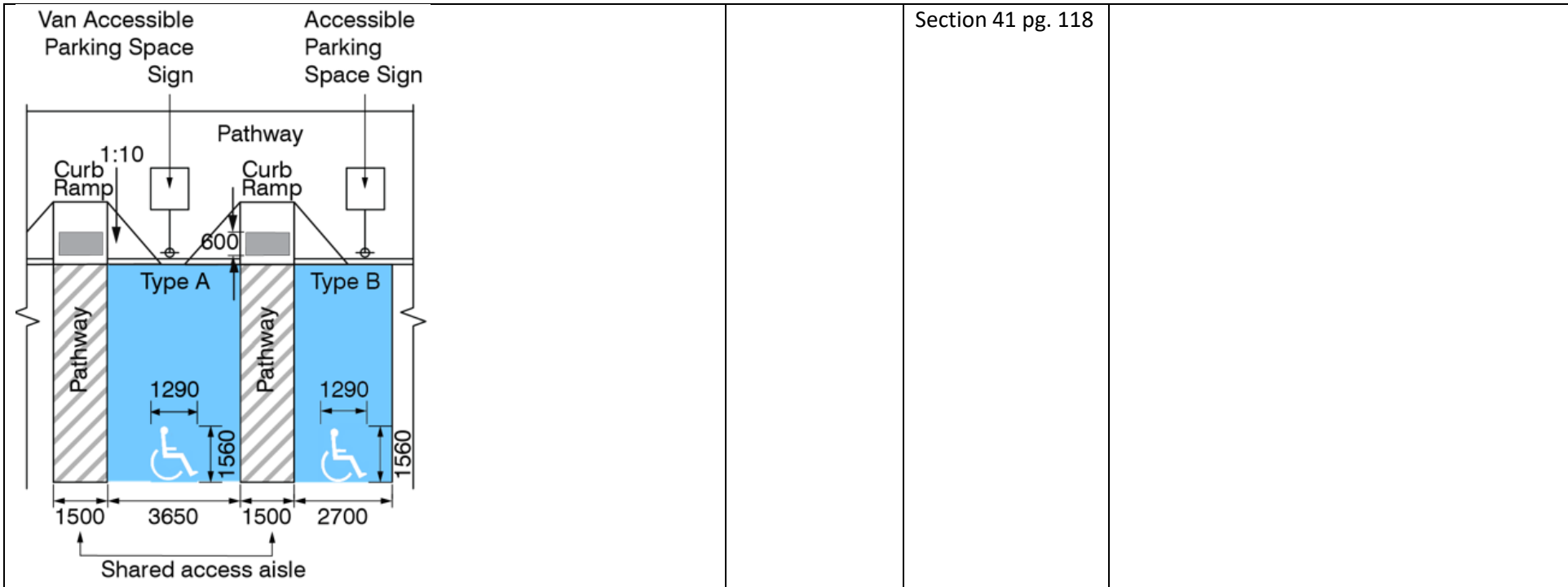

Section 41 pg. 118

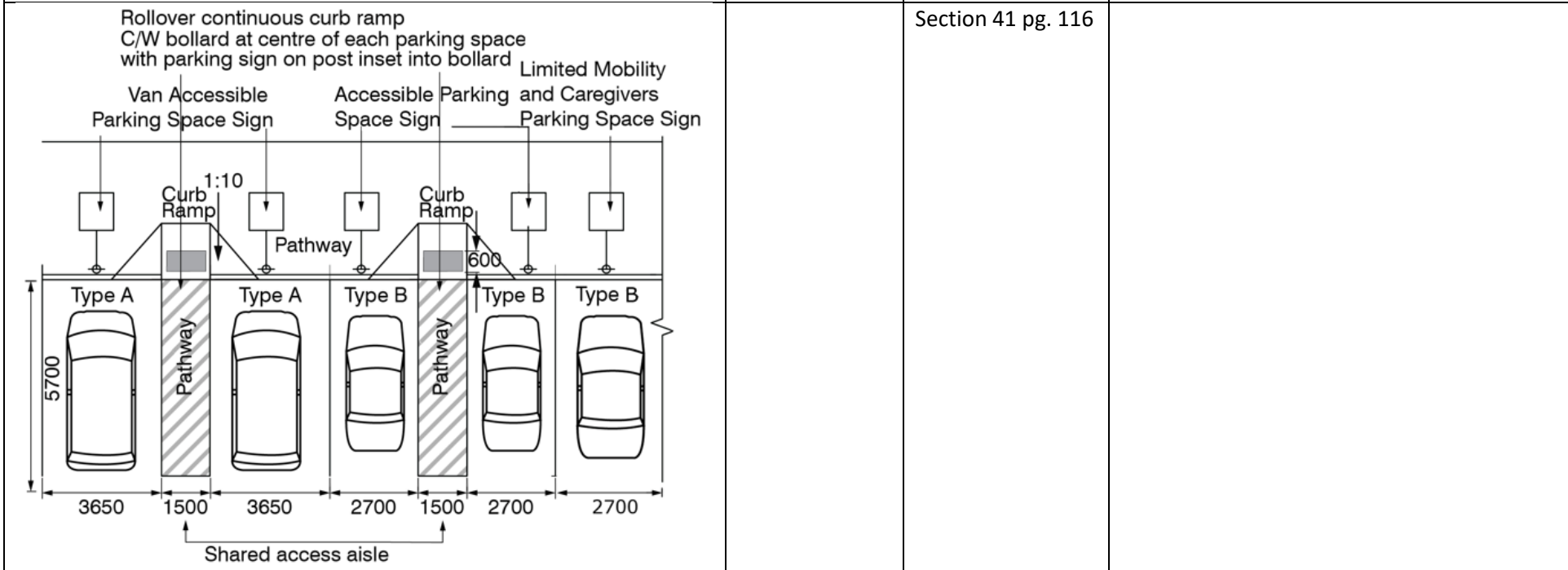

Section 41 pg. 116

Site Furniture

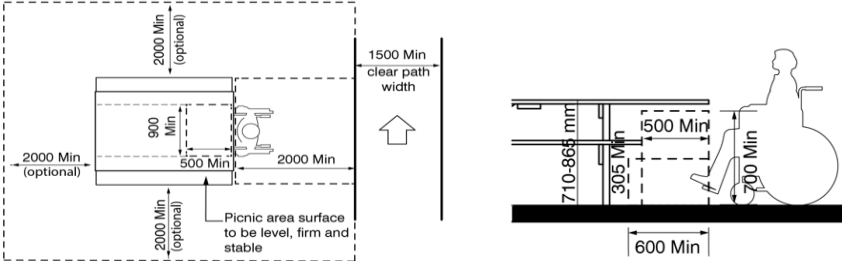
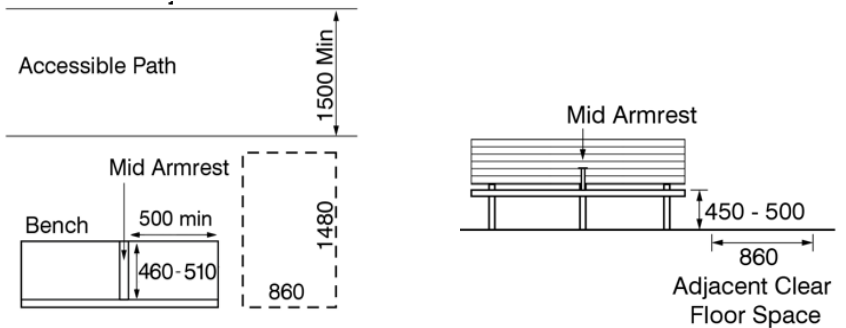
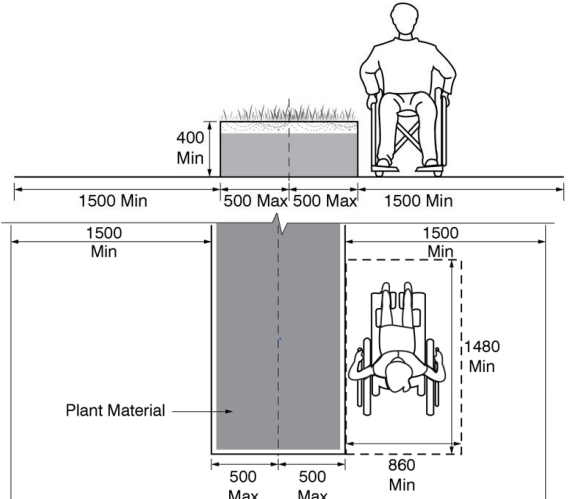
ITEM	YES / NO / N/A	FADS REFERENCE	COMMENTS
<p>Picnic Tables</p> 		Section 42 pg. 120	
<p>Benches</p> 		Section 42 pg. 119	
<p>Planting Beds</p> 		Section 45 pg. 124	

Kitchens

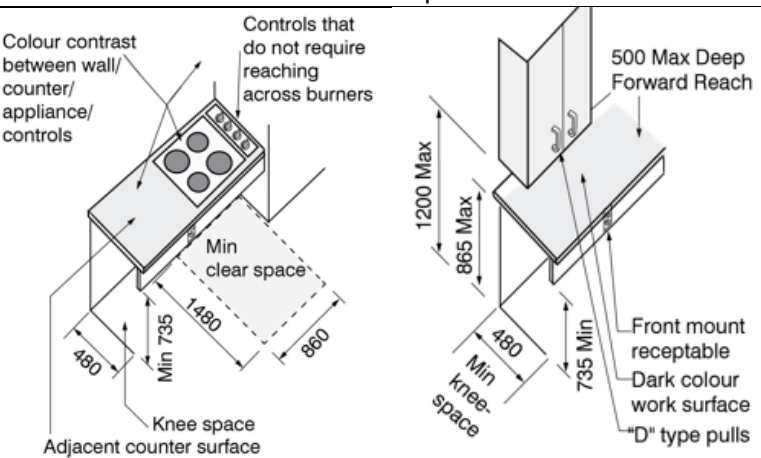
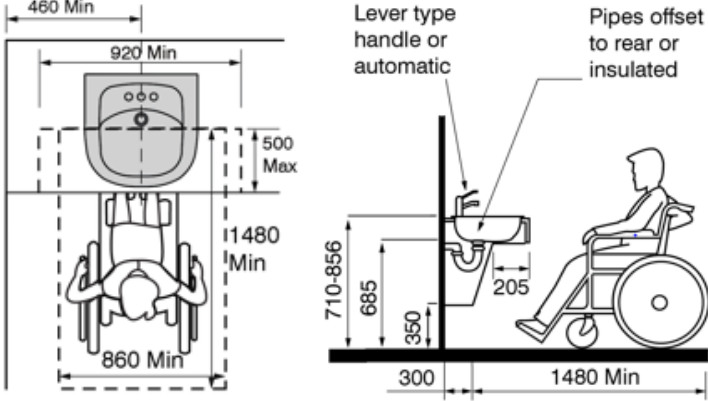
ITEM	YES / NO / N/A	FADS REFERENCE	COMMENTS
<p>Colour contrast between counter tops and cabinets and walls</p>  <p>[Diagram 29.G] Range Access [Diagram 29.D] Cabinet and Counters</p>		<p>Section 29 pg. 87 Section 29 pg. 89</p>	
 <p>[Diagram 29.F] Sink Floor Plan [Diagram 29.E] Sink and Counter Top Access</p>		<p>Section 29 pg. 89</p>	
<p>There are three options with-in the FADS document for kitchen styles: U-shape / L-shape / Galley</p>		<p>Section 29 pg. 87, 88</p>	
<p>Faucet handles must be lever type</p>		<p>Section 29 pg. 88</p>	